









# Sbrinatori vetri - Glass defrosting

## P.85

-  **Materiale - Material**  
ABS
-  **Colore - Colour**  
Nero - Black
-  **Pezzi confezione - Package items**  
50 pezzi - pieces
-  **Volume e dimensioni confezione**  
Package volume and size  
64 dm<sup>3</sup> - 400 X 400 X 400 mm
-  **Peso confezione - Package weight**  
6.350 g

### SPO Ricambi - Spare parts

-  **Sezione utile passaggio aria -**  
Open air flow section: 2.500 mm<sup>2</sup>
-  **Temp. di esercizio - Working temp.**  
-10/+70 °C (14/158 °F)

-  **Normative - Norms**  
R107.8; R118.3; FMVSS 302; ISO 3795; REACH; ROHS; CMR.  
More info on page C2-C3 and website on "Directives and regulations" area.



### ★ Accessori - Accessories

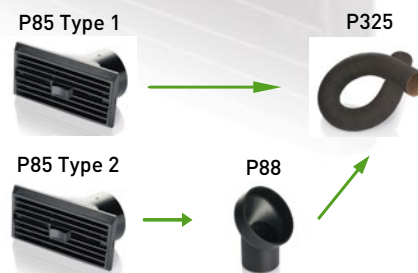

## P.85

Cod.	Tipo - Type
52050	1
68178*	2

\* Collegabile a raccordo P.88 - Connectable to P.88 connector

# Sezione tecnica - Technical section

## P.85

### tipo - type 1

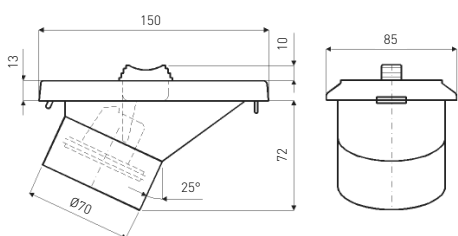

### tipo - type 2

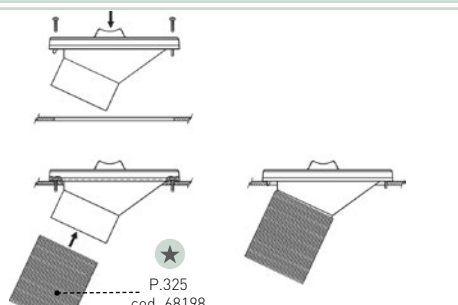
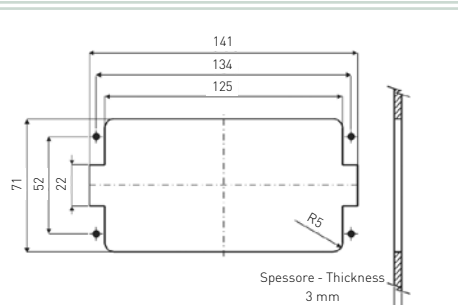
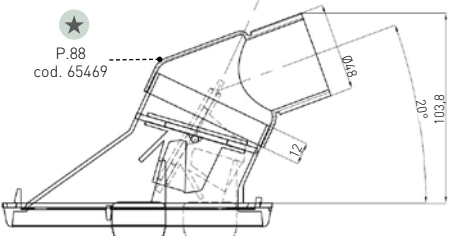

 **dima di foratura e fissaggio**  
drilling and fixing template

 **viti TP autofilettanti ø 5 mm non comprese**  
BH auto - threading screws ø 5 mm are not included