

# Tondo orientabile - Round adjustable

## P.83

**Materiale - Material**  
Poliammide + fibra vetro - Glass fibre polyamide

**Colore - Colour**  
secondo codice - according to item code

**Pezzi confezione - Package items**  
50 pezzi - pieces

**Volume e dimensioni confezione - Package volume and size**  
secondo codice - according to item code  
\* 24,3 dm<sup>3</sup> - 400 X 280 X 200 mm  
\*\* 35,2 dm<sup>3</sup> - 400 X 400 X 200 mm

**Peso confezione - Package weight**  
secondo codice - according to item code

**SPQ Ricambi - Spare parts**  
-

**★ Accessori - Accessories**



**Sezione utile passaggio aria -**  
Open air flow section: 2.280 mm<sup>2</sup>

**Temp. di esercizio - Working temp.**  
-10/+120 °C (14/248 °F)

**LEX Normative - Norms**  
R107.8; R118.3; FMVSS 302; ISO 3795; REACH; ROHS; CMR.  
More info on page C2-C3 and website on "Directives and regulations" area.

## P.83

Cod.	Tipo - Type	Colore - Colour	dm <sup>3</sup>	g	Min
66201	1	nero - black	24,3*	3.400	
65371	2	grigio - grey Ral 7001	24,3*	3.700	1000
66211	2	nero - black	24,3*	3.700	
60118	2	grigio - grey Ral 7043	24,3*	3.700	300
62561	3	nero - black	35,2**	5.200	

**Min** lotto minimo d'acquisto - minimum purchasing lot

## P.83

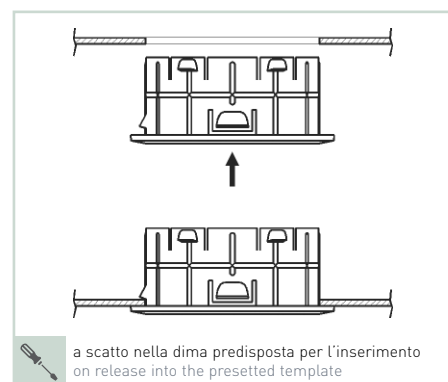
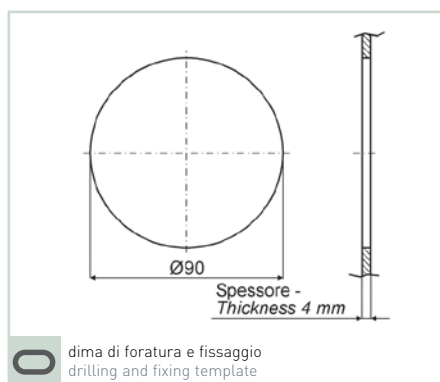
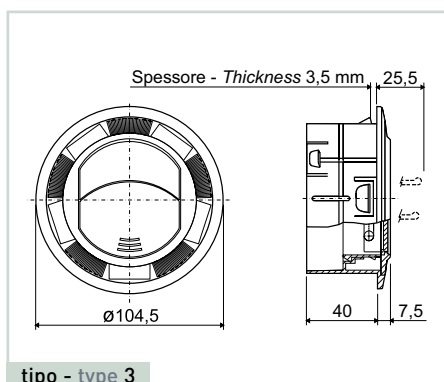
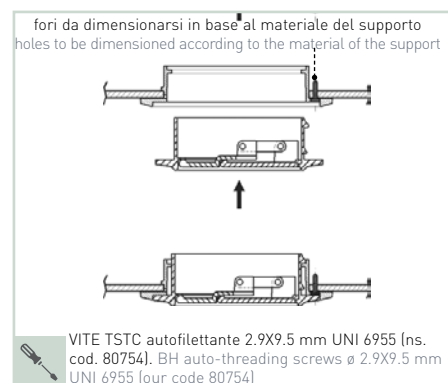
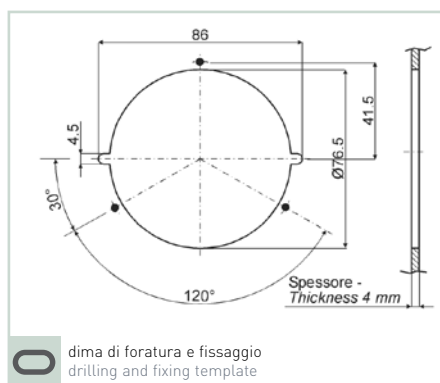
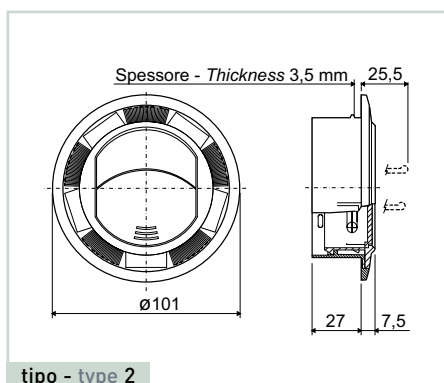
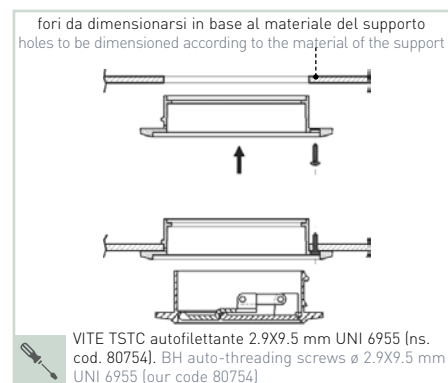
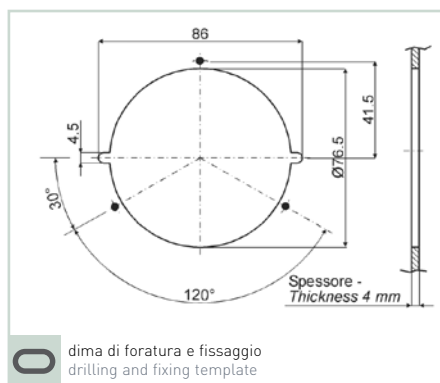
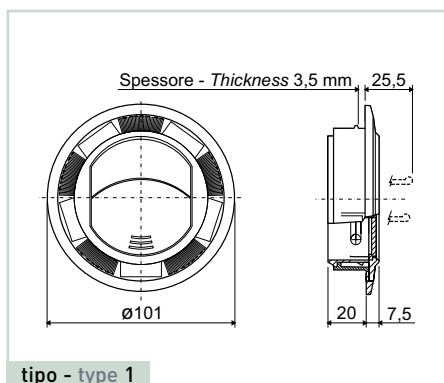

### Esempi d'applicazione - Examples of application

