

## P.386s EasySTOP slim

- Materiale - Material**  
Compound poliammide e ABS  
Polyamide and ABS compound
- Colore - Color**  
secondo codice - according to item code
- Pezzi confezione - Package items**  
50 pezzi - pieces
- Volume confezione - Package volume**  
14 dm<sup>3</sup>
- Peso confezione - Package weight**  
3.400 g
- Ricambi - Spare parts**  
vedi sez. tecnica - see technical section
- Accessori - Accessories**  
vedi sez. tecnica - see technical section
- Temp. di esercizio - Working temp.**  
-10/+120 °C
- Normative - Norms**  
pag. E2



### P.386s EasySTOP Slim Pulsanti ad ultrasuoni (senza fili) - Ultrasound push-buttons (wireless)

Frequenza Frequency Hz	Tipo di applicazione Type of application D mm	Colore - Color					
		Corpo Body	Tasto Push button				
F1=17.000	ø 30 ÷ 32	■ Ral 7040	■ Ral 3000	64242			
		■ Ral 1018	■ Ral 5015		64292		
	ø 35 ÷ 38	■ Ral 7040	■ Ral 5015	64342			
		■ Ral 7040	■ Ral 3000		64392		
		■ Ral 7040	■ Ral 5015	64442			
		■ Ral 1018	■ Ral 3000		64492		
F4=22.000	ø 30 ÷ 32	■ Ral 7040	■ Ral 5015	64272			
		■ Ral 1018	■ Ral 3000	61703			
	ø 35 ÷ 38	■ Ral 7040	■ Ral 3000	64372			
		■ Ral 7040	■ Ral 5015		64422		
		■ Ral 7040	■ Ral 3000	64472			
		■ Ral 1018	■ Ral 5015		64522		
F5=29.000	ø 30 ÷ 32	■ Ral 7040	■ Ral 3000	63603			
		■ Ral 7040	■ Ral 5015	64282			
	ø 35 ÷ 38	■ Ral 7040	■ Ral 3000	64332			
		■ Ral 7040	■ Ral 5015	64382			
		■ Ral 7040	■ Ral 3000	64482			
		■ Ral 7040	■ Ral 5015		64532		

Le scritte sui tasti, se non diversamente indicate, sono bianche - The inscriptions, if not differently indicated, are white

## P.386s EasySTOP slim

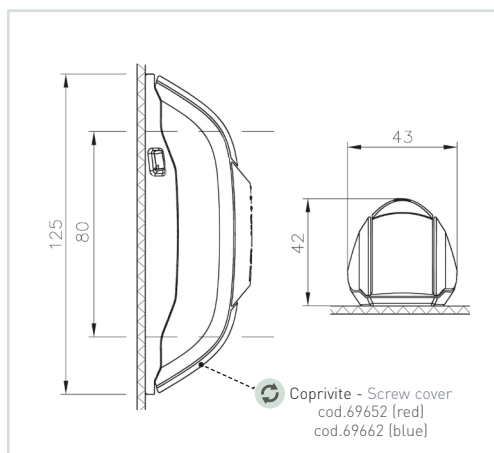
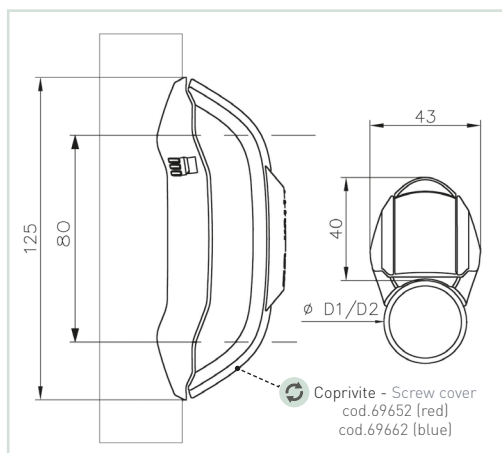

Fissaggio pulsantiere al tubo o a parete:  
viti autofilettanti  $\varnothing$  3,5 mm testa piana (non comprese nella confezione), fori di fissaggio da dimensionarsi a seconda del materiale di supporto

Tube or wall fixing:  $\varnothing$  3,5 mm autothreading flat head screws (not included in the package), fixing holes to be dimensioned according to the material of the support











- Elenco elementi già esistenti con i quali è possibile realizzare nuove combinazioni per produzioni di almeno 100 pz.  
Further combinations are possible using following existing components for minimum batches of 100 pcs.

P.386s		P.386s			
CORPO - BODY		TASTO - PUSH BUTTON			
PA6		ABS	Tipo Type	Sigle e pittogrammi disponibili (in colore nero o bianco) Inscriptions and logos available (black or white color)	
■ Ral 3000	■ Ral 5015	■ Ral 3000			
■ Ral 1018	■ Ral 1018	■ Ral 1018			
■ Ral 7040					



E

## P.386 EasySTOP

-  **Materiale - Material**  
Corpo in ABS + compound elettrico  
ABS body +electric compound
-  **Colore - Colour**  
Grigio - Grey
-  **Pezzi confezione - Package items**  
1 pezzo - piece
-  **Volume confezione - Package volume**  
2,76 dm<sup>3</sup>
-  **Peso confezione - Package weight**  
290 g
-  **Ricambi - Spare parts**  
vedi sez. tecnica - see technical section
-  **Accessori - Accessories**  
vedi sez. tecnica - see technical section
-  **Temp. di esercizio - Working temp.**  
-10/+90 °C
-  **Normative - Norms**  
pag. E2



### P.386 Kit centralina ricevente - Processing unit kit

Cod.	Tipologia - Type	Ubicazione - Fixing site	Alimentazione - Feeding	  
61103	canali in ricezione - frequencies receving: 3 (F1 - F4 - F5) uscite - contact outputs: 3	parzialmente in vista flush mounted	12 ÷ 24 V DC	•
61113*	canali in ricezione - frequencies receving: 3 (F1 - F4 - F5) uscite - contact outputs: 3	in vista panel mounted	12 ÷ 24 V DC	•
67612**	canali in ricezione - frequencies receving: 3 (F1 - F4 - F5) uscite - contact outputs: 3	in vista panel mounted	12 ÷ 24V DC	•

\* Modello adatto per installazione su veicoli aventi lunghezza superiore a 10 m - This model is suitable for application on vehicles longer than 10 m

\*\* Modello adatto per installazione su veicoli aventi lunghezza inferiore a 10 m - This model is suitable for application on vehicles longer less than 10 m

## P.386 EasySTOP

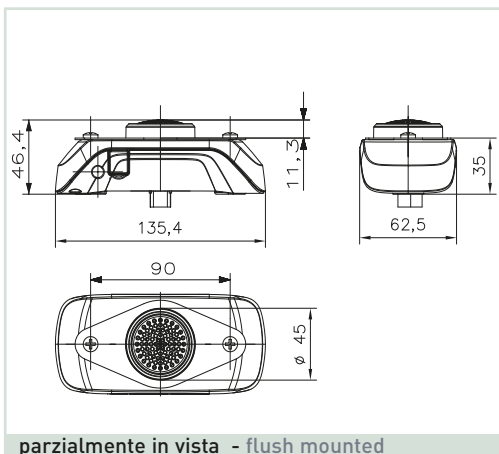

parzialmente in vista - flush mounted

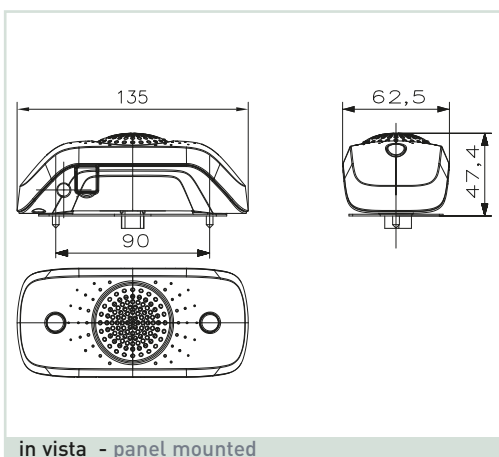
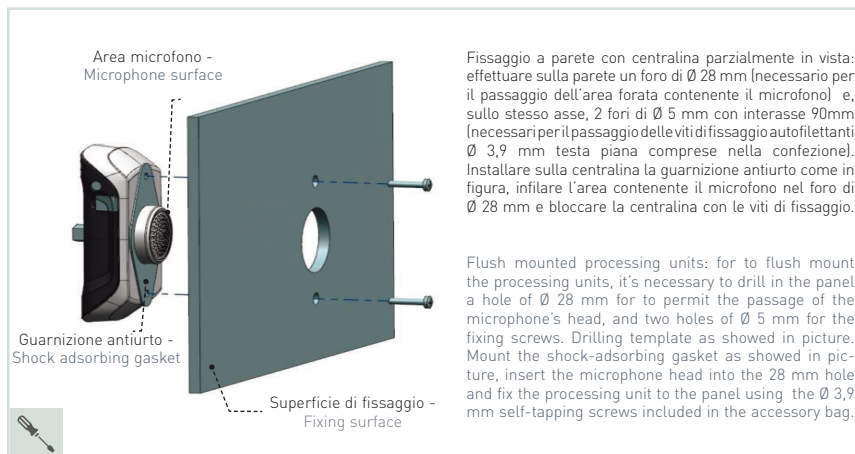

in vista - panel mounted

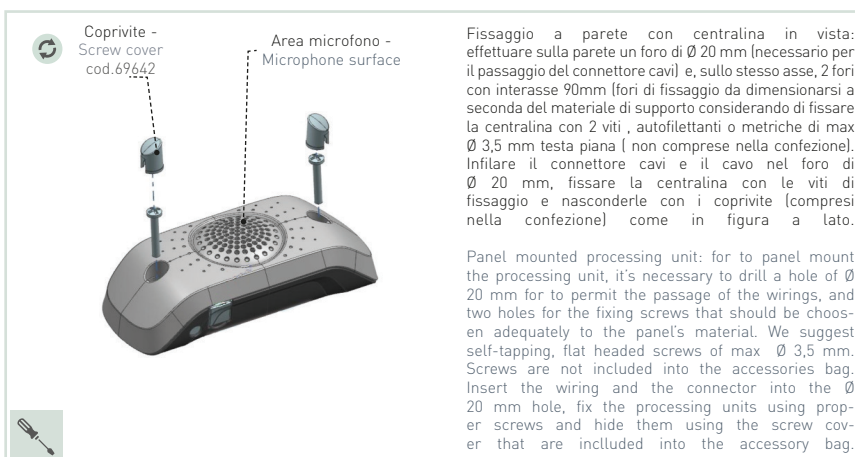

### Accessori indispensabili per il collegamento della centralina alla alimentazione e ai dispositivi di segnalazione acustica e visiva - Accessories required to connect the processing unit to the power supply and to the buzzer or to the display.

Cod.	L (mm)	Tipo - Type	▲	✕	Min
69692	5m	Cablaggio a 8 poli con connettore - 8 poles cable with terminal	•		
69702	10m	Cablaggio a 8 poli con connettore - 8 poles cable with terminal	•		
69712	20m	Cablaggio a 8 poli con connettore - 8 poles cable with terminal		•	
69682	50m	Cablaggio a 8 poli senza connettore - 8 poles cable without terminal	•		

Set completo per realizzare il connettore per il cavo di alimentazione della centralina - Complete set to realize the connector for the feeding cable of the unit cod.69672

