



Cappelliere per bus urbani e intercity Luggage racks for citybus and intercity

P.1450 BASIC

-  **Materiale - Material**
Struttura in Alluminio, poliammide fibra vetro
Aluminium frame, glass fibre polyamide
-  **Colore - Color**
NCS S 5020-Y20R or NCS S 7005-Y20R
-  **Lotto minimo - Minimum lot**
5 pezzi - pieces
-  **Volume confezione - Package volume**
Secondo componenti, vedi pag. L20
According to components, see pag. L20
-  **Peso confezione - Package weight**
Secondo componenti - According to components
-  **Normative - Norms**
R107.8; R118.3; FMVSS 302; ISO 3795; REACH; ROHS; CMR.
More info on page F2 and website on "Directives and regulations" area.



P.1450 BASIC

Cod.	Tipo - Type	L (mm)			 Striscia/Strip LED
63673	2 porta anteriore front door	A) 4.000 B) 5.000	A) 5x2 seats B) 5x1 seats	75 Kg	
63683	1 porta ant e/o post front and/or back door	A) 5.000 B) 6.000	A) 5x2 seats B) 6x2 seats	85 Kg	Led strip 24V Led strip 24V

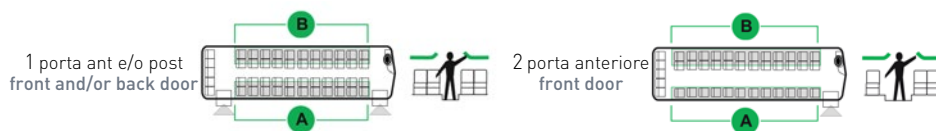

Sezione tecnica - Technical section

P.1450 BASIC

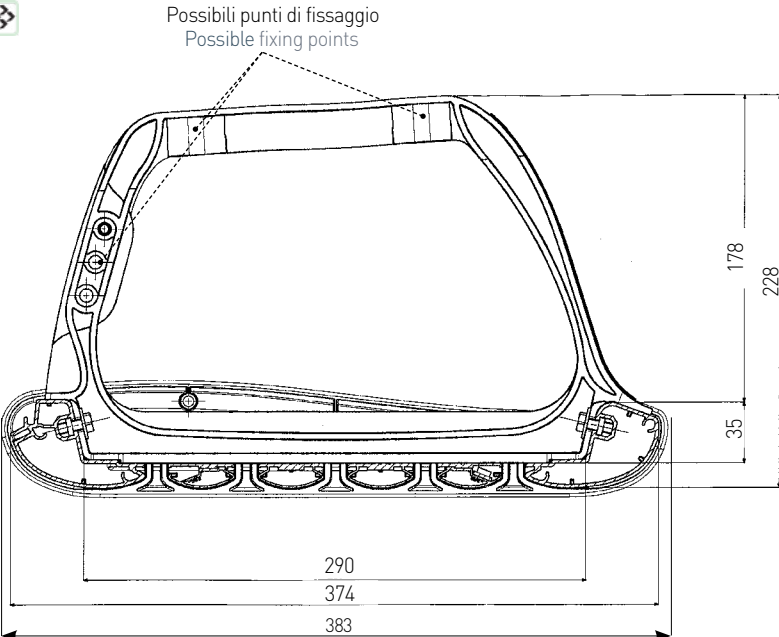

-  **Peso - 6,5 Kg/m circa**
Weight - 6,5 Kg/m about
- Resistenza alla trazione - 100 Kg/m lineare**
Load traction - 100 Kg/linear m
- E' possibile fissare la cappelliera in maniera tradizionale (lato finestrino bus) oppure sospesa in maniera autonoma sul tetto**
It's possible to fix the luggage rack in the traditional way (window side on the bus) or suspended independently on the roof
- Tutte le staffe di supporto possono essere posizionate liberamente in senso longitudinale**
All the brackets for support can be placed freely along the longitudinal direction
- Possibilità di avere il mancorrente conformato in modo da poter accogliere l'illuminazione di tipo indiretta tramite strisce led 12/24V**
Possibility to have the handrail profile conformed in order to include the indirect lighting by led strips 12/24V